

PARTS LIST			
ITEM	QTY	PART NUMBER	DESCRIPTION
1	1	2216-004-1	SS HINGE MAIN PLATE - T304
2	1	2216-004-2	SS HINGE PIN 65 O/A - T304
3	1	2216-004-3	SS HINGE MOUNTING PLATE - T304
4	1	GREASE NIPPLE	GREASE NIPPLE

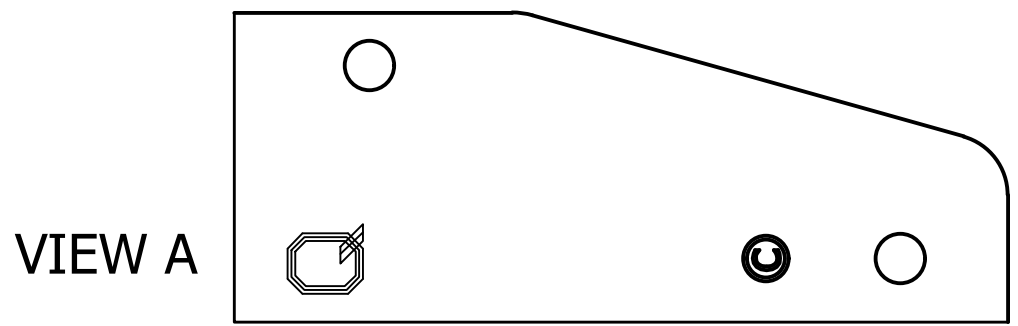
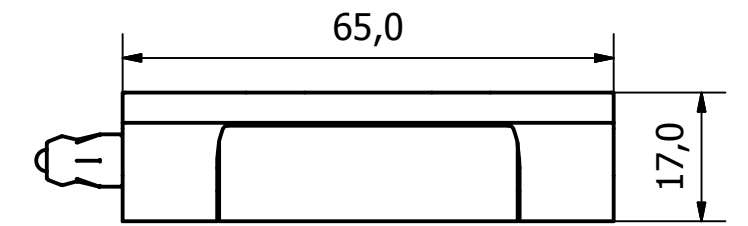
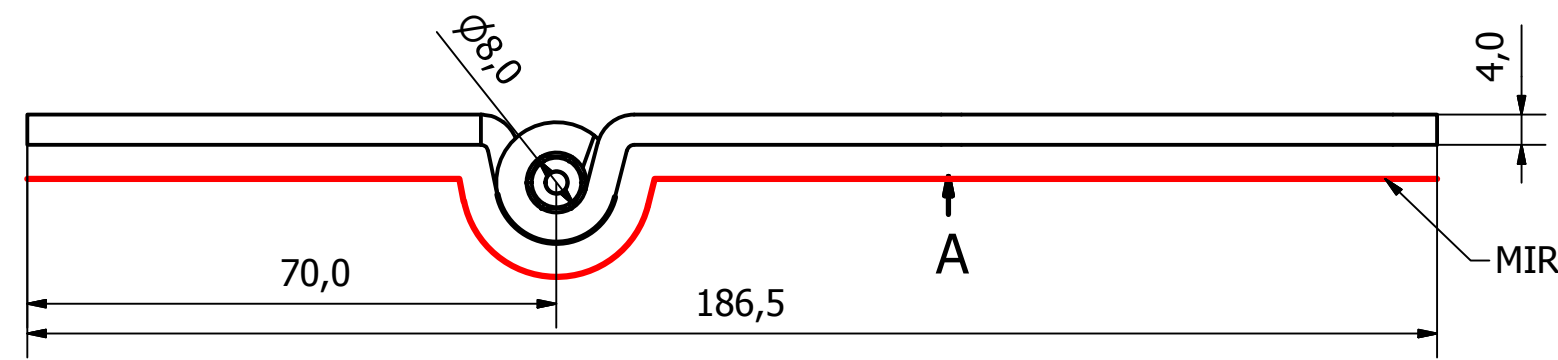
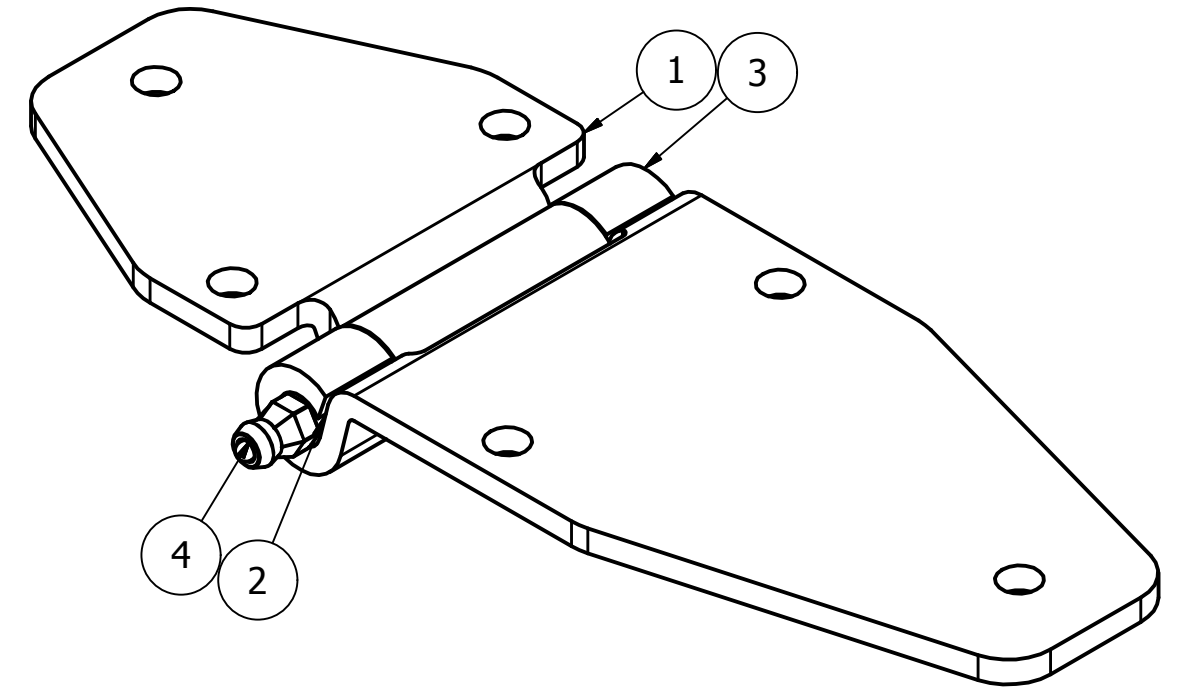
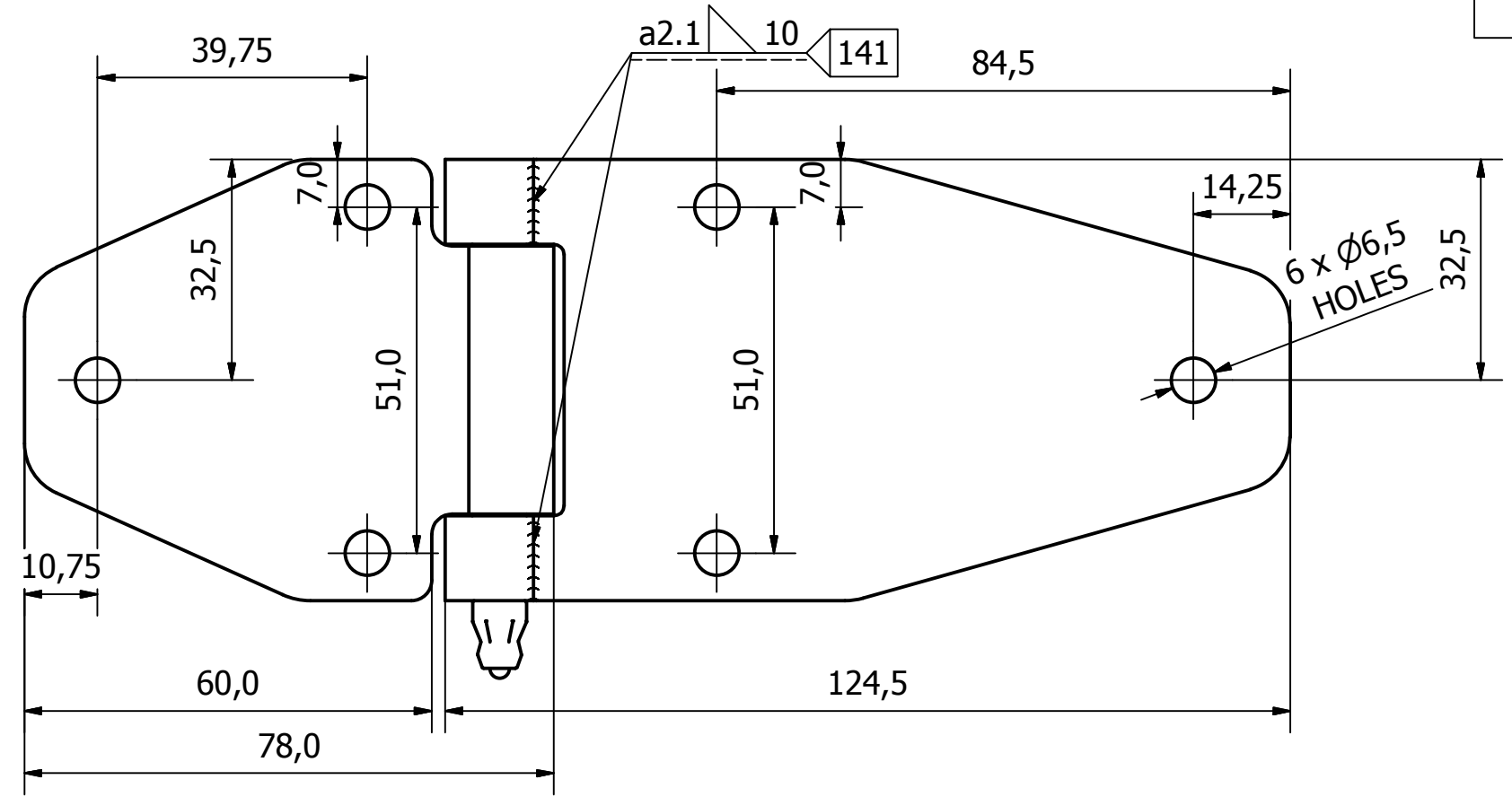

NOTE:
HINGE DESIGN FOR 180° APPLICATIONS
BUT WILL ROTATE THROUGH 270°

GENERAL TOLERANCES ON LENGTHS
0.5 - 6 ± 0.1mm
6 - 30 ± 0.2mm
30 - 120 ± 0.3mm
120 - 400 ± 0.5mm
400 - 1000 ± 0.8mm
1000 - 1200 ± 1.2mm
2000 - 4000 ± 2.0mm

ALBERT JAGGER LTD
GREEN LANE
WALSALL PHONE: 01922 471000
WEST MIDLANDS FAX: 01922 648021
WS2 8HG

THIS DRAWING & THE DESIGN SHOWN
ARE THE PROPERTY OF ALBERT JAGGER LTD
AND MUST NOT BE USED OR COPIED BY A
THIRD PARTY WITHOUT PERMISSION

DRAWN BY
U.F

CHECKED BY
A.P

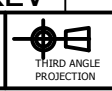

SCALE
1 : 1

MATERIAL
-

MASS
0.394 kg

FINISH
SEE NOTE

Date
28/09/2016

ALL DIMS IN MM
UNLESS STATED
DO NOT SCALE

A3

1	VALIDATION COMPLETE	04/11/16	A.P
REV	DESCRIPTION	DATE	APPROVED
	SS PRESSED STEEL HINGE - T304		
2216-004		Edition 1	Sheet 1 / 1

