

IF IN DOUBT ASK

ITEM NO.	PART NUMBER	DESCRIPTION	QTY.
1	2217-004-1	CARBON STEEL HINGE BASE	1
2	2217-004-2	BRASS BEARING WASHER	1
3	2217-004-3	CARBON STEEL MOUNTING BLOCK	1

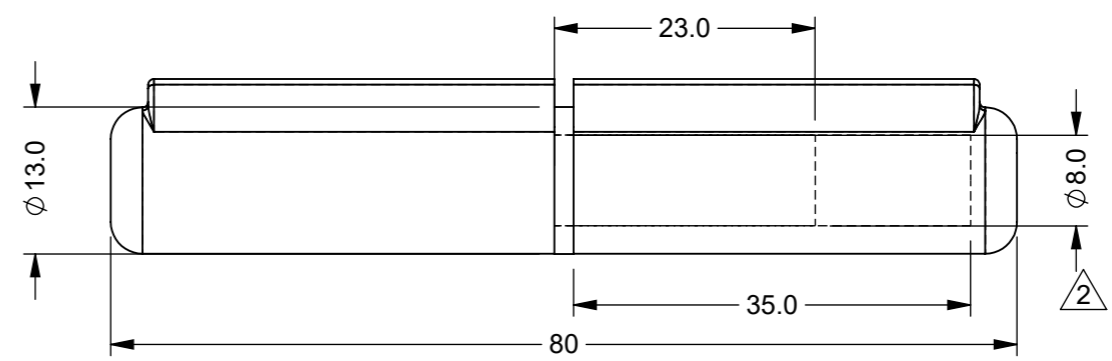
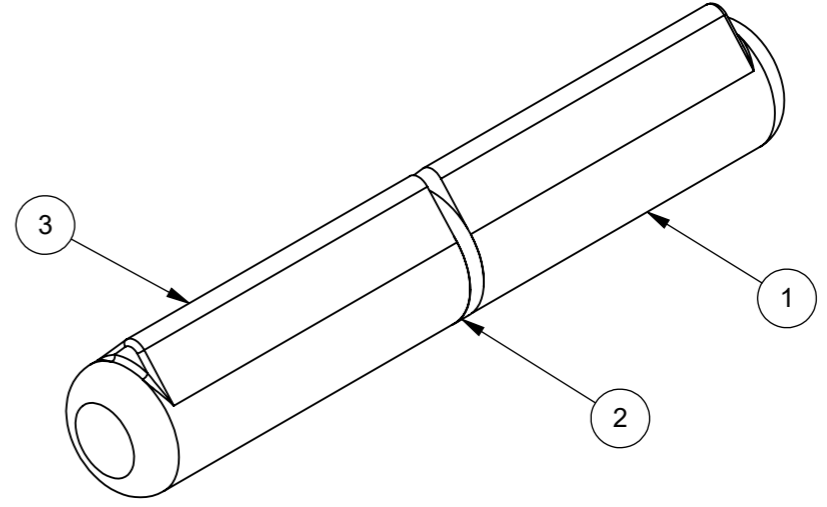
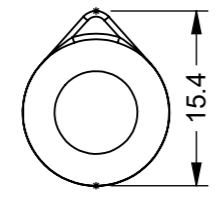
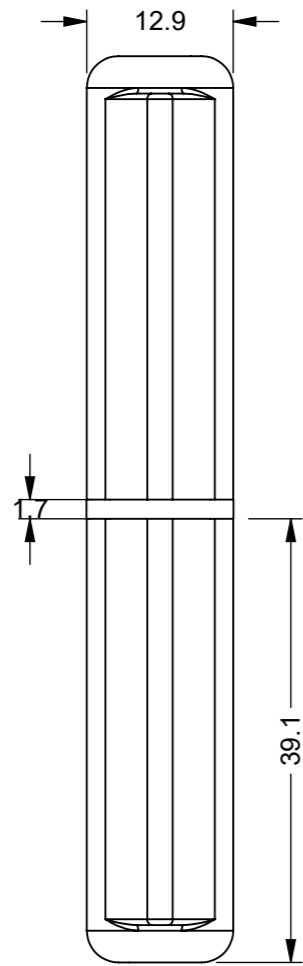

ZONE	REV.	DESCRIPTION	DATE	APPROVED
E2	2	RE-DRAWN IN SOLIDWORKS	20/11/2023	L.B.H

REVISIONS

UNLESS OTHERWISE STATED, ALL DIMENSIONS IN mm	
TOLERANCES	
0.5 - 6 = ±0.1mm	SURFACE FINISH 1.6µm Ra
6 - 30 = ±0.2 mm	FILLET RADII 0.5 TO 1.0
30 - 120 = ±0.3 mm	SQUARENESS 0.05 IN 25
120 - 400 = ±0.5 mm	PARALLELISM 0.05 IN 25
400 - 1000 = ±0.8 mm	RUNOUT 0.1
1000 - 2000 = ±1.2 mm	ANGLES ±0.5°
2000 - 4000 = ±2.0 mm	

MATERIAL: SEE TABLE	DRAWN BY: L.B.H	DESCRIPTION: WELD ON LIFT OFF HINGE - 80 O/A	A3
MASS: 0.08	CHECKED BY: U.F		
FINISH: NATURAL	APPROVED BY: A.P	NUMBER: 2217/004	REVISION: 2
	ORIGINATION DATE: 21/11/2023	SHEET: 1 of 1	
		SCALE : PROPORTIONAL - DO NOT SCALE REF SCALE 1:1 WHEN PRINTED ON A3	PROJECTION 3rd ANGLE

PROPRIETARY RIGHTS ARE INCLUDED IN THE INFORMATION DISCLOSED HEREIN. NEITHER THIS DOCUMENT NOR ANY INFORMATION DISCLOSED SHALL BE REPRODUCED, USED, TRANSFERRED TO OTHER DOCUMENTS, OR DISCLOSED TO OTHERS FOR ANY PURPOSE INCLUDING MANUFACTURING UNLESS SPECIFICALLY AUTHORISED IN WRITING
REMOVE ALL SHARP EDGES AND BURRS
PART FINISHING AND MARKING TO CESF001

