

IF IN DOUBT ASK

ITEM NO.	PART NUMBER	DESCRIPTION	QTY.
1	2217-026.iam	S/STEEL HINGE BASE	1
2	2217-026-02	S/STEEL BEARING WASHER	1
3	2217-026-03	S/STEEL MOUNTING BLOCK	1

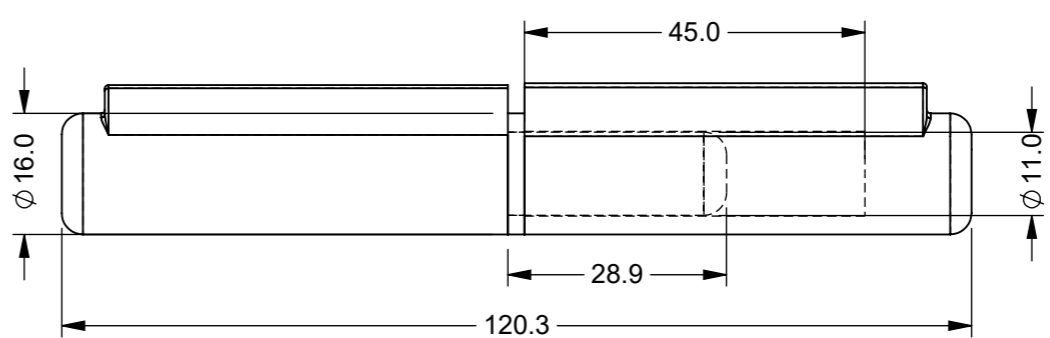
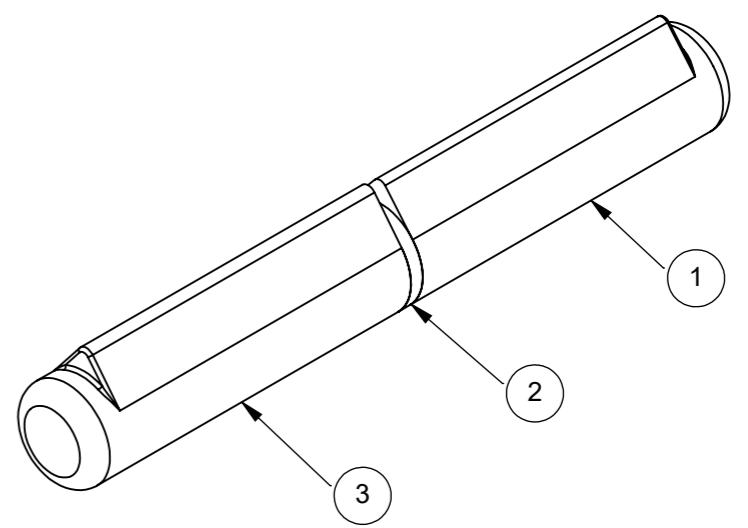
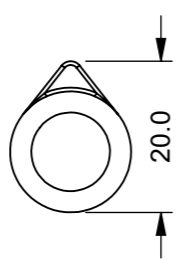
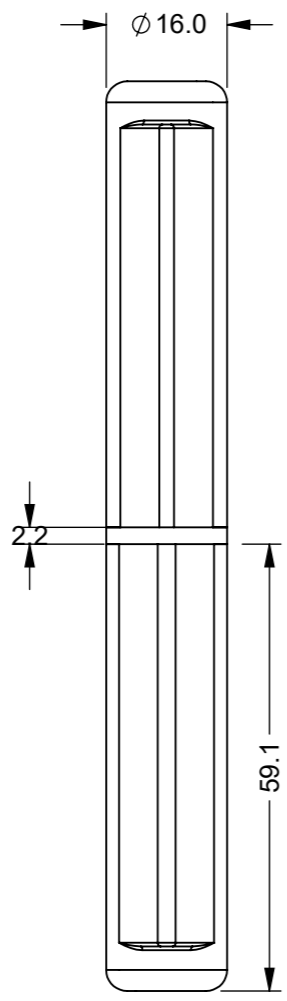

ZONE	REV.	DESCRIPTION	DATE	APPROVED
	2	RE-DRAWN IN SOLIDWORKS & ADDED DIMS	01/08/2023	S.R

UNLESS OTHERWISE STATED, ALL DIMENSIONS IN mm

TOLERANCES		SURFACE FINISH 1.6um Ra	
0.5 - 6	= ±0.1mm	FILLET RADII	0.5 TO 1.0
6 - 30	= ±0.2 mm	SQUARENESS	0.05 IN 25
30 - 120	= ±0.3 mm	PARALLELISM	0.05 IN 25
120 - 400	= ±0.5 mm	RUNOUT	0.1
400 - 1000	= ±0.8 mm	ANGLES	±0.5°
1000 - 2000	= ±1.2 mm		
2000 - 4000	= ±2.0 mm		

MATERIAL: SEE TABLE	DRAWN BY: SR	DESCRIPTION: S/STEEL WELD ON HINGE - 120.3 O/A			A3
MASS: 0.195KG	CHECKED BY: AP	NUMBER: 2217-026	REVISION: 2	SHEET: 1 of 1	
FINISH: NATURAL	APPROVED BY: AP	ORIGINATION DATE: 01/08/2023	SCALE : PROPORTIONAL - DO NOT SCALE REF SCALE 1:1 WHEN PRINTED ON A3		

PROPRIETARY RIGHTS ARE INCLUDED IN THE INFORMATION DISCLOSED HEREIN. NEITHER THIS DOCUMENT NOR ANY INFORMATION DISCLOSED SHALL BE REPRODUCED, USED, TRANSFERRED TO OTHER DOCUMENTS, OR DISCLOSED TO OTHERS FOR ANY PURPOSE INCLUDING MANUFACTURING UNLESS SPECIFICALLY AUTHORIZED IN WRITING
REMOVE ALL SHARP EDGES AND BURRS
PART FINISHING AND MARKING TO CESF001

