

PARTS LIST			
ITEM	QTY	PART NUMBER	DESCRIPTION
1	1	3802-CL24-1	ZINC DIE-CAST LOCK BODY - CHROME POLISHED
2	1	3802-CL24-2	ZINC DIE-CAST LATCH - CHROME POLISHED
3	1	3802-CL24-3	ZINC DIE-CAST RELEASE BUTTON - CHROME POLISHED
4	1	3802-CL24-4	ZINC DIE-CAST LOCK BARREL - CHROME POLISHED
5	1	3802-BL24M-5	S/STEEL LATCH PIN - NATURAL
6	1	3802-BL24M-6	S/STEEL BUTTON PIN - NATURAL
7	1	3802-BL24M-7	M/STEEL CLAMP - Z/C PASSIVATED
8	1	3802-BL24M-8	M/STEEL M5 CLAMP SCREW - Z/C PASSIVATED
9	1	3802-BL24M-9	M/STEEL M5 LOCK WASHER - Z/C PASSIVATED
10	1	3802-BL24M-10	M/STEEL M5 GRIP RANGE SCREW - Z/C PASSIVATED
11	1	3802-BL24M-11	M/STEEL M5 NUT - Z/C PASSIVATED
12	1	3802-BL24M-12	RUBBER GASKET - BLACK

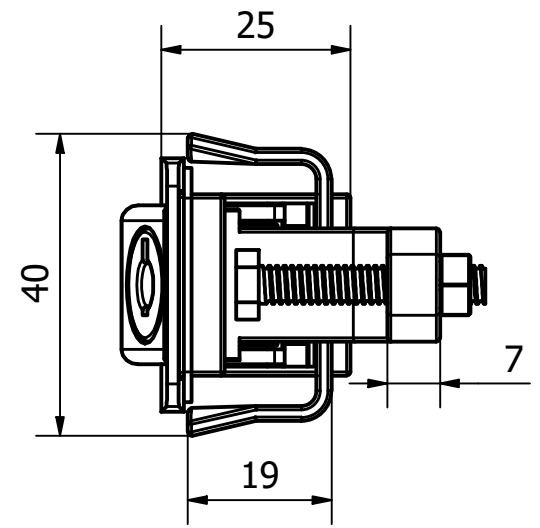
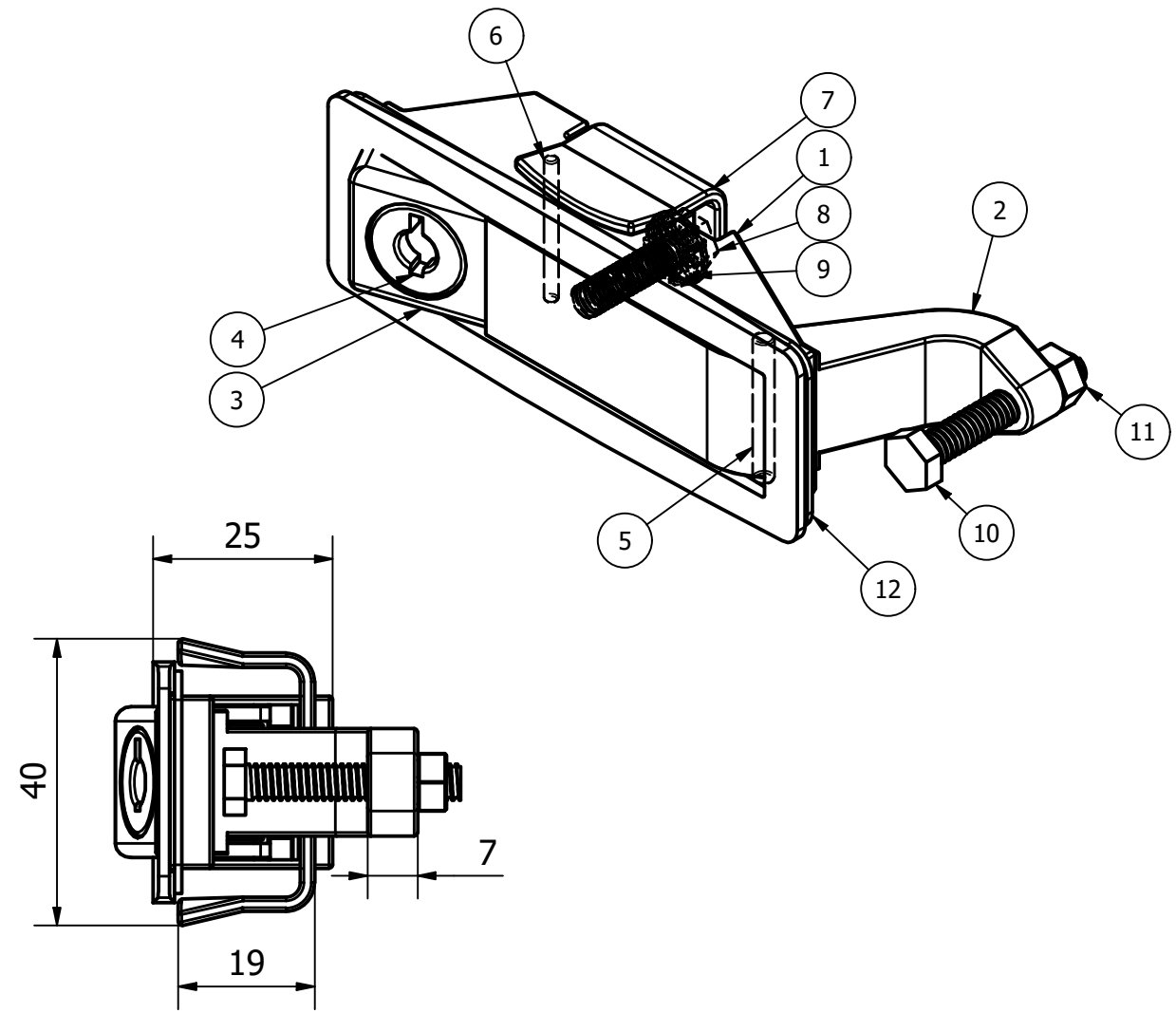

REV	DESCRIPTION	DATE	APPROVED
2	CUT OUT DETAILS ADDED	06/04/22	U.F
1	VALIDATION COMPLETE	25/02/20	A.P

NOTE:  
GRIP RANGE 1-24mm  
USES KEY CH751

GENERAL TOLERANCES ON LENGTHS	
0.5 - 6 ± 0.1mm	
6 - 30 ± 0.2mm	
30 - 120 ± 0.3mm	
120 - 400 ± 0.5mm	
400 - 1000 ± 0.8mm	
1000 - 2000 ± 1.2mm	
2000 - 4000 ± 2.0mm	

ALBERT JAGGER LTD  
GREEN LANE  
WALSALL PHONE: 01922 471000  
WEST MIDLANDS FAX: 01922 648021  
WS2 8HG

THIS DRAWING & THE DESIGN SHOWN ARE THE PROPERTY OF ALBERT JAGGER LTD AND MUST NOT BE USED OR COPIED BY A THIRD PARTY WITHOUT PERMISSION

DRAWN BY U.F  
CHECKED BY A.P



SCALE	MATERIAL	MASS	FINISH	Date	ALL DIMS IN MM UNLESS STATED DO NOT SCALE	A3
1 : 1	SEE TABLE	0.187 kg	SEE TABLE	24/02/2020		
CHROME LOCKING COMPRESSION LATCH - KEY CH751						
3802-CL24					Edition 2	Sheet 1 / 1