

PART NUMBER	MATERIAL	FINISH
11705-15	CRS, 1008/1010, 16 GA	⑦ COAT PER ES-104

REVISION	ECN	ECN BY	DESCRIPTION
5	10191	CML 10/20/97	REDRAWN ON CAD; REVISED PART NAME; SECTION A-A WAS SECTION B-B; DETAIL B WAS DETAIL A
6	10435	CML 4/20/98	2X .195±.025 WAS 2X .195; 2X .245±.030 WAS 2X .245; FLUSH TO .025 WAS FLUSH TO .020 (2)
7	21558	GDE 10/07/08	UPDATED: FINISH, FORMAT. .20±.01 WAS .200±.010.

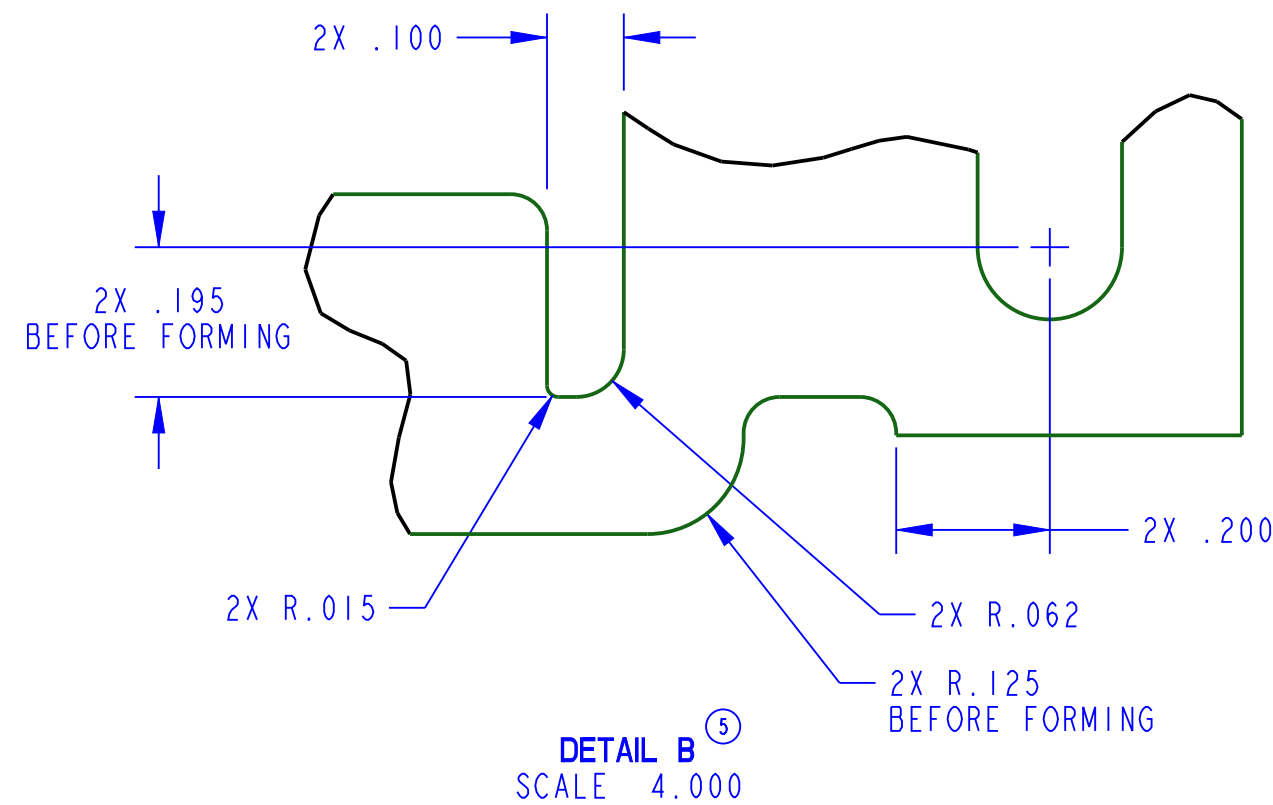
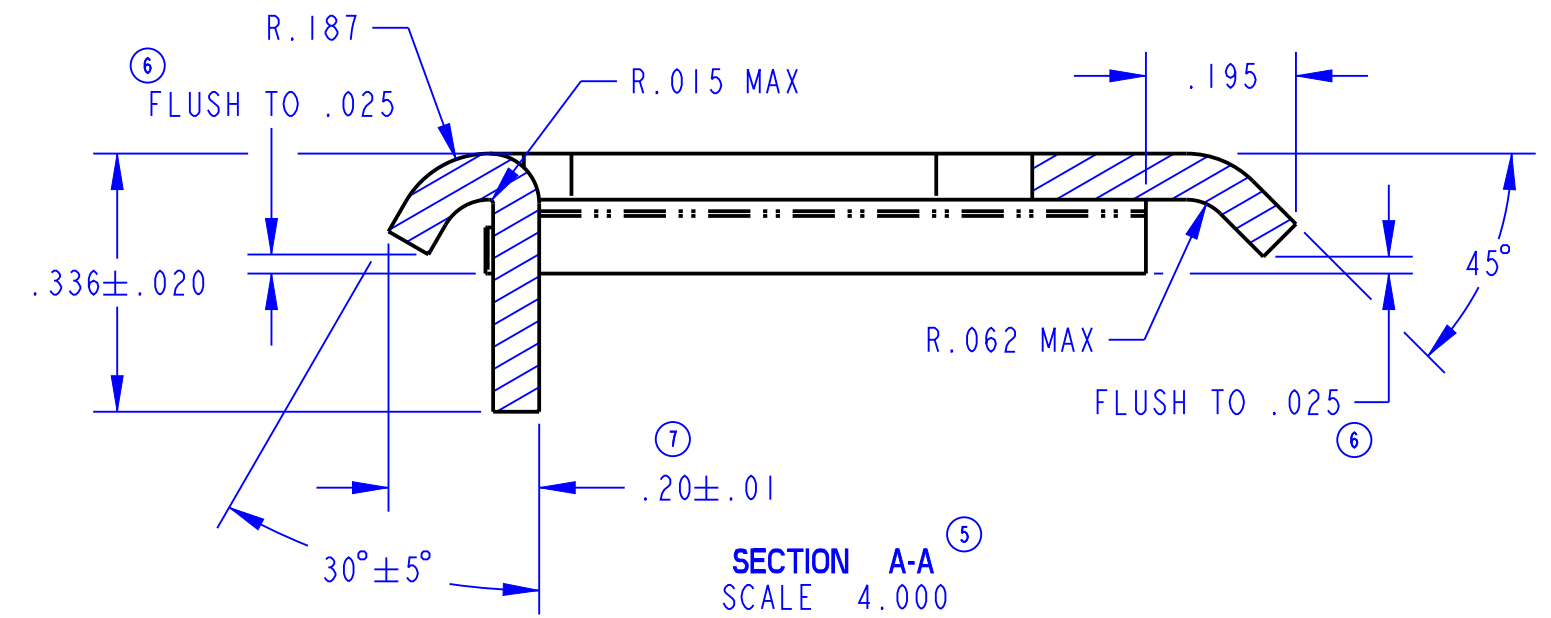
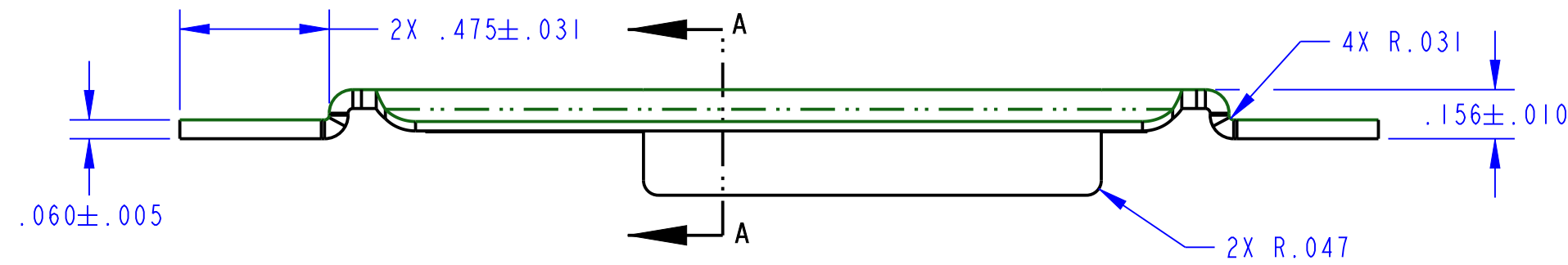
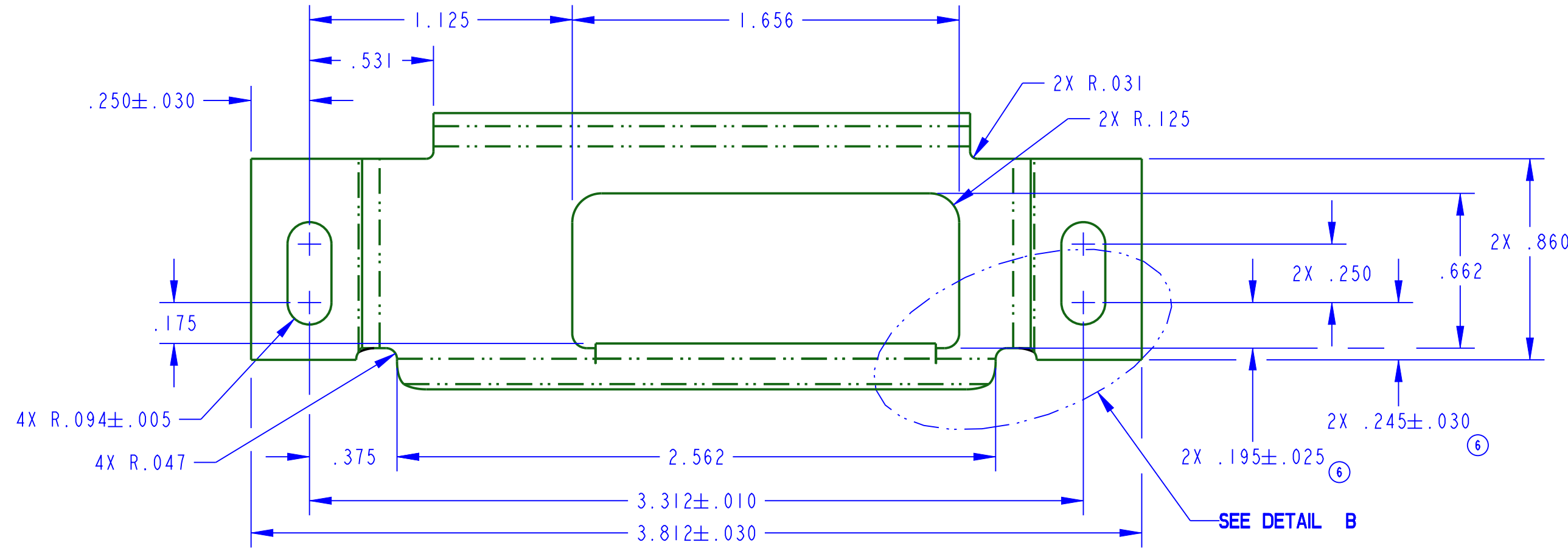

DIMENSIONS	ANGLES
X.X = ±.1	X° = ± 3°
X.XX = ±.03	
X.XXX = ±.015	

<p>● INDICATES REQUIRED ASSEMBLY INFORMATION. UOS: THE -00 VERSION SHALL BE THE UNFINISHED VERSION OF PART SHOWN. UOS: ALL DIMENSIONS APPLY BEFORE COATING. (ASME Y14.5M, sec. 2.4.1)</p>		
<p>TOLERANCES UNLESS OTHERWISE SPECIFIED (UOS) ASME Y14.5M-1994</p>		
	<p>DRAWN BY KPE 10/11/88</p>	<p>CHECKED BY SLG 12/15/88</p>
<p>PROJECT L88036-1</p>	<p>PRODUCT CODE K05 (100-0500)</p>	
<p>CUSTOMER</p>		
<p>CUSTOMER PART NUMBER</p>		
<p>PART WEIGHT (0.06 LB)</p>	<p>SURFACE AREA (7.76 IN²)</p>	<p>SIZE C</p>
<p>REF. T/M OP 4.20-2 FOR SUP. QUALITY REQ. REF. T/M OP 4.20-3 FOR INT. QUALITY REQ.</p>		<p>SCALE 2.0</p>
<p>DO NOT SCALE DRAWING</p>		<p>PART NUMBER 11705-XX</p>

TriMark
 500 Bailey Avenue
 P. O. Box 350
 New Hampton, Iowa 50659 U.S.A.
 Tel: 641-394-3188
 Fax: 641-394-2392

This drawing and the information contained herein is the property of TriMark Corporation and shall not be used for any purpose without our written consent.

DESCRIPTION	SIZE	SCALE	PART NUMBER
PLATE, STRIKE, DEADBOLT	C	2.0	11705-XX